

AT-AMC1 Carrier Blade

AdvancedTCA™ AdvancedMC™ Carrier Blade with 2 or 4 Bays – AMC.1 Compliant

Features

- 2 or 4 bay ATCA carrier blade
- Supports extended full-height AdvancedMCs
- x2 Gigabit Ethernet (GbE) interface to all AMC bays (Common Options Region)
- x4 PCI Express (PCIe) interface to AMC bays 1, 3, and 4 (Fat Pipes Region)
- x8 PCIe interface to AMC bay 2 (Fat Pipes Region)
- x2 GbE ports for base interface to ATCA backplane
- x4 GbE ports for fabric interface to ATCA backplane
- PICMG 3.0 update channel
- Supports carrier and AMC hot swap
- Supports telecom master clock generation, distribution and control
- AMC.3 (SAS/SATA) compliant
- Rear transition module (RTM) support

Architecture

- AMC.1 and AMC.2 compliant module interconnects via PCIe and GbE to Common Options Region and Fat Pipes Region
- Dual star topology
- Supports Automatic Protection Switching (APS)
- Comprehensive Baseboard Management Controller supporting an IPMI v1.5 subsystem

Product Reliability

- High MTBF
- Technical support for OEM customers and resellers

The AT-AMC1 is an AMC.1 compliant AdvancedTCA (ATCA) carrier blade that is available with two or four bays. The AT-AMC1 supports up to four extended full-height, single-width AdvancedMCs (AMCs) or up to two extended full-height, double-wide AMCs.

The serial fabric interface to each of the AT-AMC1's AMC slots complies with the AMC.1 and AMC.2 Specifications for the Common Options and Fat Pipes regions. One AMC bay supports x8 PCIe interfaces (AMC.1 Type 8) on AMC ports 4-11; the other three AMC bays accommodate x4 PCIe interfaces (AMC.1 Type 4) on AMC ports 4-7. These lanes can be configured x1, x2, x4, or x8 depending upon AMC performance requirements. Gigabit Ethernet (GbE) is supported on AMC ports 0 and 1 (AMC.2 Type E2). These GbE lanes can be used as control / data points and for redundancy purposes. The PCIe and GbE lanes each terminate into a high performance non-blocking switch. The AT-AMC1 is also AMC.3 compliant via AMC ports 2 and 3 enabling support for applications requiring storage I/O (SAS/SATA) AdvancedMCs.

AT-AMC1 is designed to deliver carrier services for any AMC.1-compliant AMC including processor, WAN I/O, LAN I/O or storage AMCs. This allows the carrier blade to be optimized for high-performance architectures that support next-generation IP-centric applications such as IP Multimedia Subsystem (IMS) and Fixed Mobile Convergence (FMC).

Two GbE interfaces to the base interface and four GbE interfaces to the fabric interface are connected to the backplane for high speed data transfer.

Intelligent Platform Management Interface & Hot Swap Compliance

The Baseboard Management Controller supports an Intelligent Platform Management Interface (IPMI) v1.5 subsystem that performs E-keying, module power distribution, system clock distribution, and module hot swap sequencing. E-keying allows the system to identify which slots have installed AMCs and to manage the serial fabric lane configurations. The power distribution subsystem recognizes and performs power management for each AMC slot. The AT-AMC1 is hot swappable and field-replaceable in accordance with PICMG 3.0. The carrier blade's IPMI firmware is upgradeable providing investment protection.



AT-AMC1 Carrier Blade AdvancedTCA AdvancedMC Carrier Blade with 2 or 4 Bays

Specifications

PICMG/AMC Compliance

- PICMG 3.0/3.1 Specification
- AMC.1 Type 4
- AMC.1 Type 8
- AMC.2 Type E2
- AMC.3
- IPMI v1.5 firmware; upgradeable

Form Factor

- PICMG 3.0 compliant

Power Requirements

- 40 watts/bay

Weight

- 1.6 kg (3.5 lbs)

Environmental

- Operating temperature: -5°C to +55°C
- Storage temperature: -40°C to +85°C
- Storage relative humidity: 5 – 95% non-condensing

Regulatory Compliance

- Emissions
 - FCC 47 CFR Part 15 Class A (USA)
 - EN 55022:1998, A1:2000, A2:2003 Class A ITE(EU)
 - ICES -003 Issue 3 Class A (Canada)
 - AS/NZ CISPR 22:2002
 - VCCI Class A ITE
 - Class A (Aus. New Zealand)
 - VCCI Class A ITE
- Immunity
 - EN 55024:1998/A1:2001/A2:2003 (EU)
- Safety
 - UL60950-1 (USA)
 - CSA 22.1 No. 60950-1-03 (Canada)
 - EN 60950-1 (EU)
- CE Mark

Block Diagram

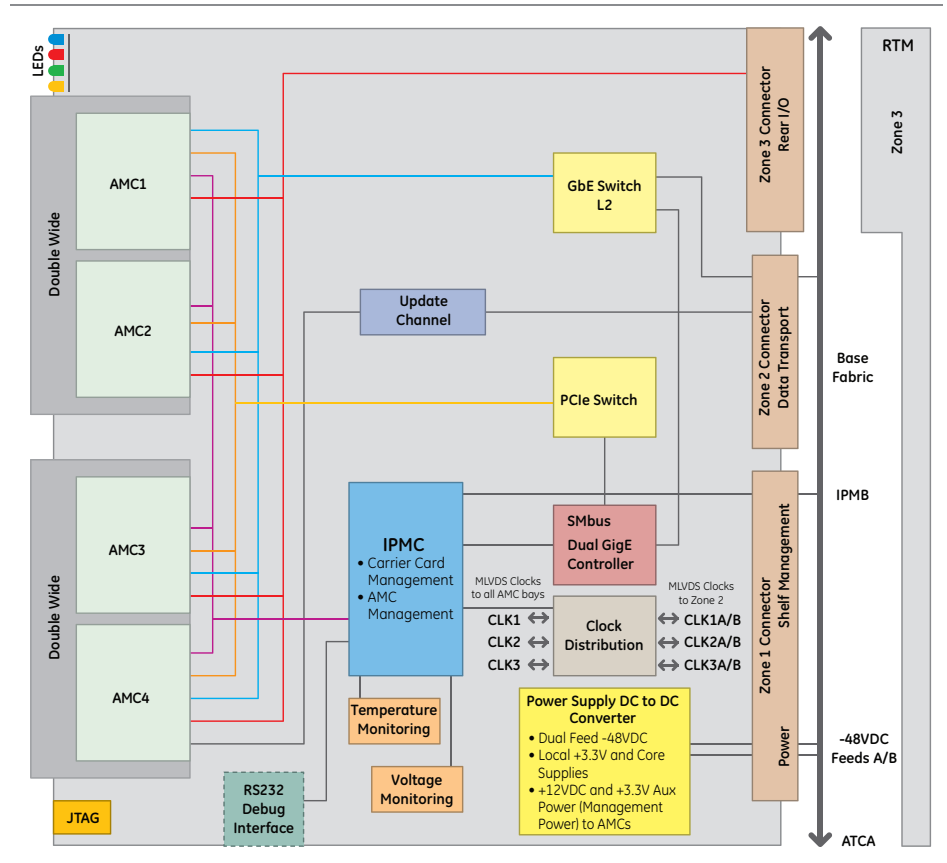

Ordering Information

15021-101

AT2-AMC1 ATCA carrier blade with two double-width bays

15021-102

AT4-AMC1 ATCA carrier blade with four single-width bays

Refer to the Telum product family datasheets for additional information on processor, WAN I/O, LAN I/O and storage I/O AdvancedMCs.

About GE Fanuc Embedded Systems

GE Fanuc Embedded Systems is a leading global provider of embedded computing solutions for a wide range of industries and applications. Our comprehensive product offering includes many types of I/O, single board computers, high performance signal processors, fully integrated, rugged systems including flat panel displays, plus high speed networking and communications products. The company is headquartered in the U.S. and has design, manufacturing and support offices throughout the world. Whether you're looking for one of our standard products or a fully custom solution, GE Fanuc Embedded Systems has the breadth, experience and 24/7 support to deliver what you need. For more information, visit www.gefanucembedded.com.

GE Fanuc Embedded Systems Information Centers

Americas:
1 800 322 3616 or 1 256 880 0444

Asia Pacific:
86 10 6561 1561

Europe, Middle East and Africa:
+49 821 5034-0

Additional Resources

For more information, please visit the GE Fanuc Embedded Systems web site at:

www.gefanucembedded.com

